

Industrial Solutions

Impact crushers

The ideal crushers for medium-hard to hard material



thyssenkrupp



Our solutions for the hardest jobs

When it comes to the crunch, crushing systems from thyssenkrupp Industrial Solutions offer the ultimate in performance, reliability and cost-effectiveness. With us as your partner, you can expect the optimum, customized solution for even the most demanding of jobs.

Call on our services and you can count on a wealth of experience and constant innovative drive. As a leading manufacturer of machines and plants for the mining, quarrying, aggregate and cement industries, we supply well-engineered crushing systems that have stood the test of time in the hardest service conditions. At the same time, we invest in intensive research and development work to make proven solutions even better and to adapt to changing demands.



From top:

Stationary single-shaft impact crusher fed by two apron feeders at Cementos Progreso S.A., Guatemala
 Type PB 200/250 CR
 Throughput rate 1,100 t/h

Mobile impact crusher with hydraulic walking mechanism at Martin Marietta, Texas, USA
 Type PB 250/300 CR
 Throughput rate 4,500/2,700 t/h

Mobile wheel-mounted impact crusher at SPCC Southern Province Cement Co., Bishah, Saudi Arabia
 Type PB 200/250 CR
 Throughput rate 1,100 t/h



Whether a standard or special design thyssenkrupp Industrial Solutions can provide the optimum solution to meet your needs. Our flexibility is a major plus: We act on your specific requirements and adapt our systems to suit the material to be crushed and the product size required, optimizing proven technology according to your specifications. The benefits of our systems are numerous: high throughput coupled with low costs, minimum maintenance, ease of operation and maximum reliability.

Fields of application and design characteristics

thyssenkrupp impact crushers are suitable for both coarse and fine crushing.

They crush medium-hard to hard material mainly where a high crushing ratio and a cubical, stress-free end product are required, and they are used: for limestone, gypsum, slag, overburden and stone; for the selective crushing of ore-bearing material; in the chemical industry for pyrite, barite, bauxite, etc..

thyssenkrupp manufactures impact crushers with throughputs of more than 4,000 t/h, available as stationary, semi-mobile or mobile units. Mobile plants may be rail-bound, mounted on crawlers or wheels, or they may be fitted with hydraulic walking mechanisms.



Stationary impact crusher plant (left) at Cemex, Hermosillo, Mexico
 Type PB 200/250
 Throughput rate 1,200 t/h

Right, from top:

Semi-mobile impact crusher plant at Jura Cement, Wildeg, Switzerland
 Type PB 180/200 CR
 Throughput rate 700 t/h <80 mm
 250 t/h <35 mm

Stationary impact crusher plant at Loma Negra S.A., Olavarria, Argentina
 Type PB 140/300
 Throughput rate 900/600 t/h

Semi-mobile impact crusher plant at Loma Negra S.A., Olavarria, Argentina
 Type PB 220/300
 Throughput rate 2,200 t/h

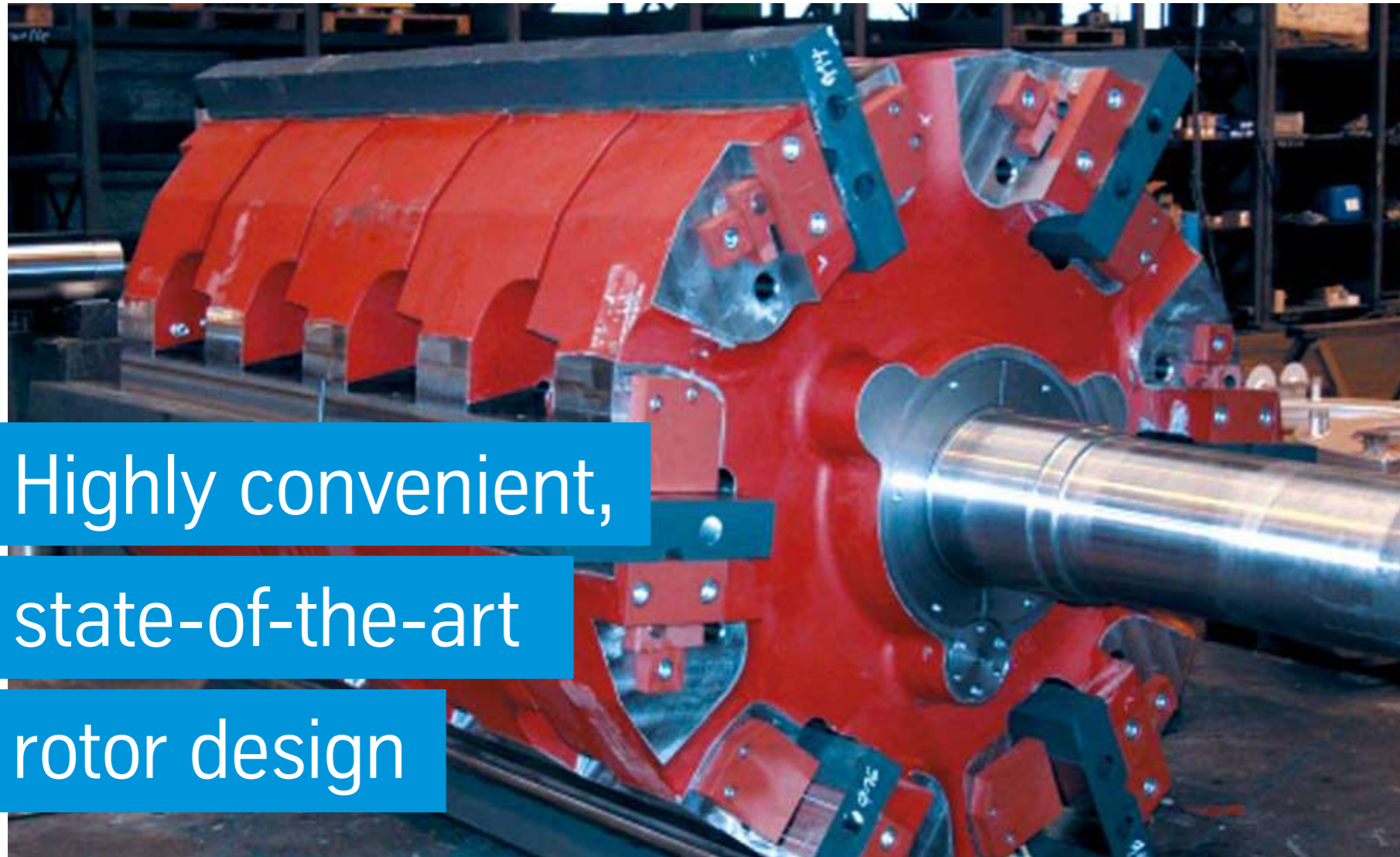

Highly convenient,
state-of-the-art
rotor design

To optimize the crushing process thyssenkrupp has developed a high-performance cast rotor. Standard cast discs are arranged on a main shaft according to the required width of the rotor. The state-of-the-art rotor discs maximize the mass moment of inertia of the rotor, allowing thyssenkrupp impact crushers to achieve high crushing efficiency.

The discs are not welded together, but fixed in place using clamping sets, allowing the rotor end discs to be replaced separately (design feature exclusively available from thyssenkrupp Industrial Solutions). This obviates the need to replace the entire rotor due to wear to the end faces.



Cast rotor (top)
Type PB 200/250 CR
Diameter 2,000 mm
Width 2,500 mm

Cast rotor (bottom)
Type PB 220/300 CR
Diameter 2,200 mm
Width 3,000 mm

Hydraulically mounted impact bars

thyssenkrupp impact crushers are equipped with extra-large impact bars which exhibit a greater wear volume. In addition, the shape of the rotor and the impact bars have been optimized, meaning that a nominal wear volume of up to 50% can be achieved with a single set of the extremely wear-resistant bars. To achieve this high wear volume, the impact bars simply need to be turned once. It is no longer necessary to raise the bars gradually, and this results in high availability and reduced downtimes for maintenance purposes.

The impact bars are attached by means of hydraulic clamping devices, and are therefore quick and easy to replace.

The quick-release bolts in the shell and the devices for positioning the rotor and replacing the impact bars allow a set of impact bars to be turned or replaced completely in less than one shift.

This improved maintenance concept combined with the low investment costs involved now ensure that thyssenkrupp impact crushers are extremely cost-effective to operate even when used for highly abrasive materials.

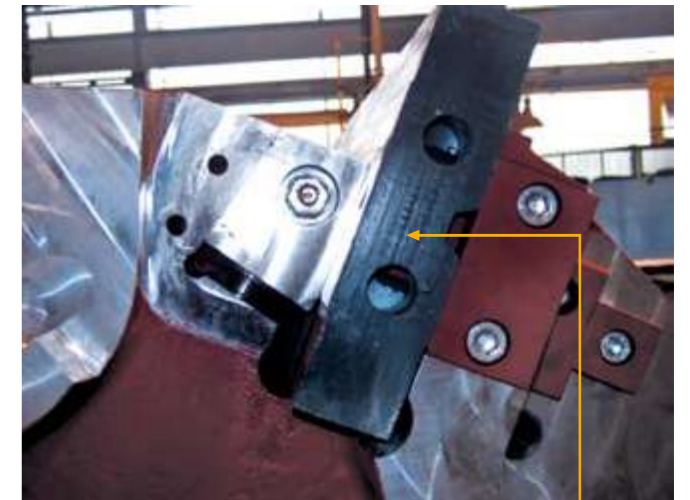

Hydraulic clamping device

Impact bar

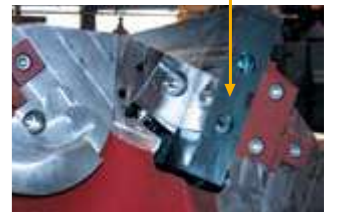
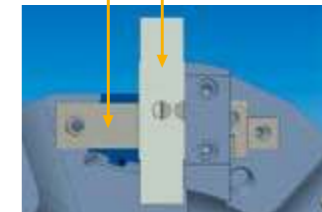

Hydraulically mounted impact bars

Effective tramp iron protection

A thyssenkrupp-patented feature to tackle the problem of uncrushable materials, such as tramp iron, in the feed, our impact crushers are equipped with effective overload protection.

Essentially, the grinding path is combined with the lower impact face. As soon as an overload situation occurs at the lower impact face, the overload cylinder relieves, widening the gap between the impact face and the rotor. At the same time, the grinding path is moved backwards, as it is connected to the lower impact face. This widens the crushing gap between the rotor and the grinding path before the tramp iron passes through, effectively minimizing or preventing any damage.

Once the uncrushable material has been discharged to the crusher discharge belt, the hydraulic cylinders move the impact face and the grinding path back to their original position. This not only provides effective protection for the crusher, but also protects downstream machines. If an overload situation occurs, the crusher discharge belt is stopped at a defined point so that the offending pieces of tramp metal can be removed.

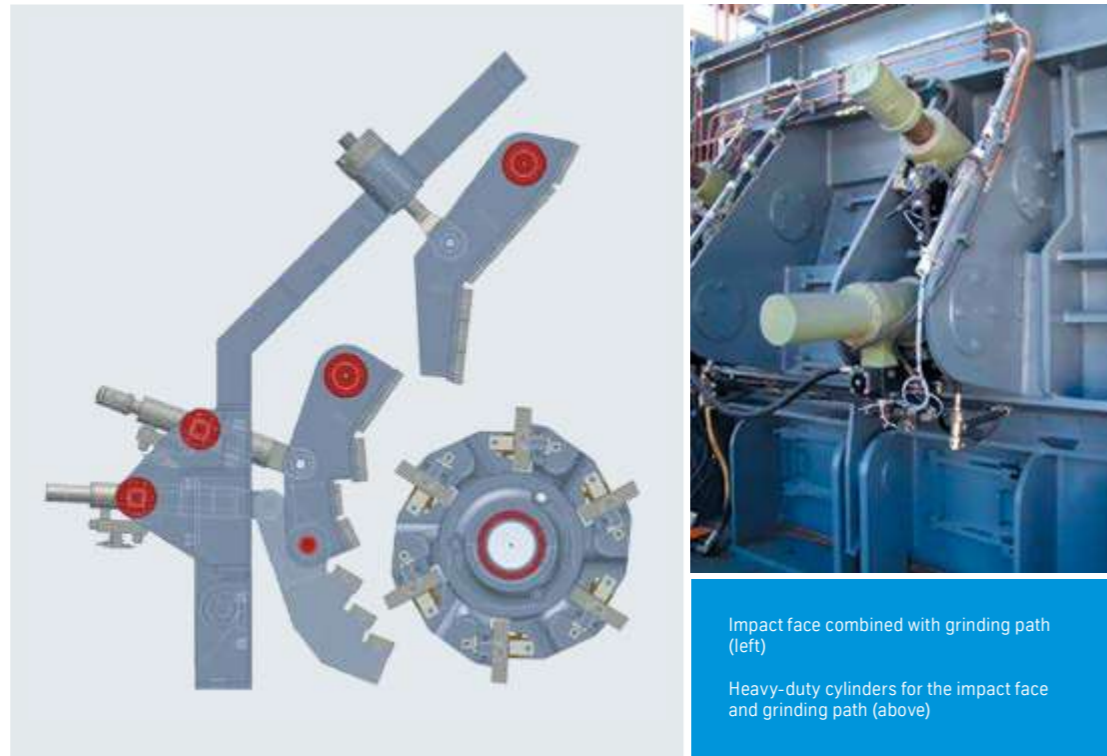

Hydraulic gap adjustment

The impact faces and the grinding path in thyssenkrupp impact crushers are adjusted hydraulically.

The lower impact face and the grinding path are also pre-loaded by means of robust hydraulic cylinders. Using these cylinders, the gap between the rotor, the impact faces and the grinding path can be adjusted locally or via the plant control system to allow different product sizes to be produced using the same crusher. It is therefore possible to crush limestone for raw mills (0-80 mm) or limestone as an additive for cement mills (0-35 mm) using the same crusher without the need for time-consuming modifications.

A further advantage of this sophisticated pretensioning system is that the crushing gap can be infinitely adjusted to compensate for wear to the impact bars and the liner plates of the impact faces and the grinding path. The system ensures that the crushing gap and thus the product size stay the same.

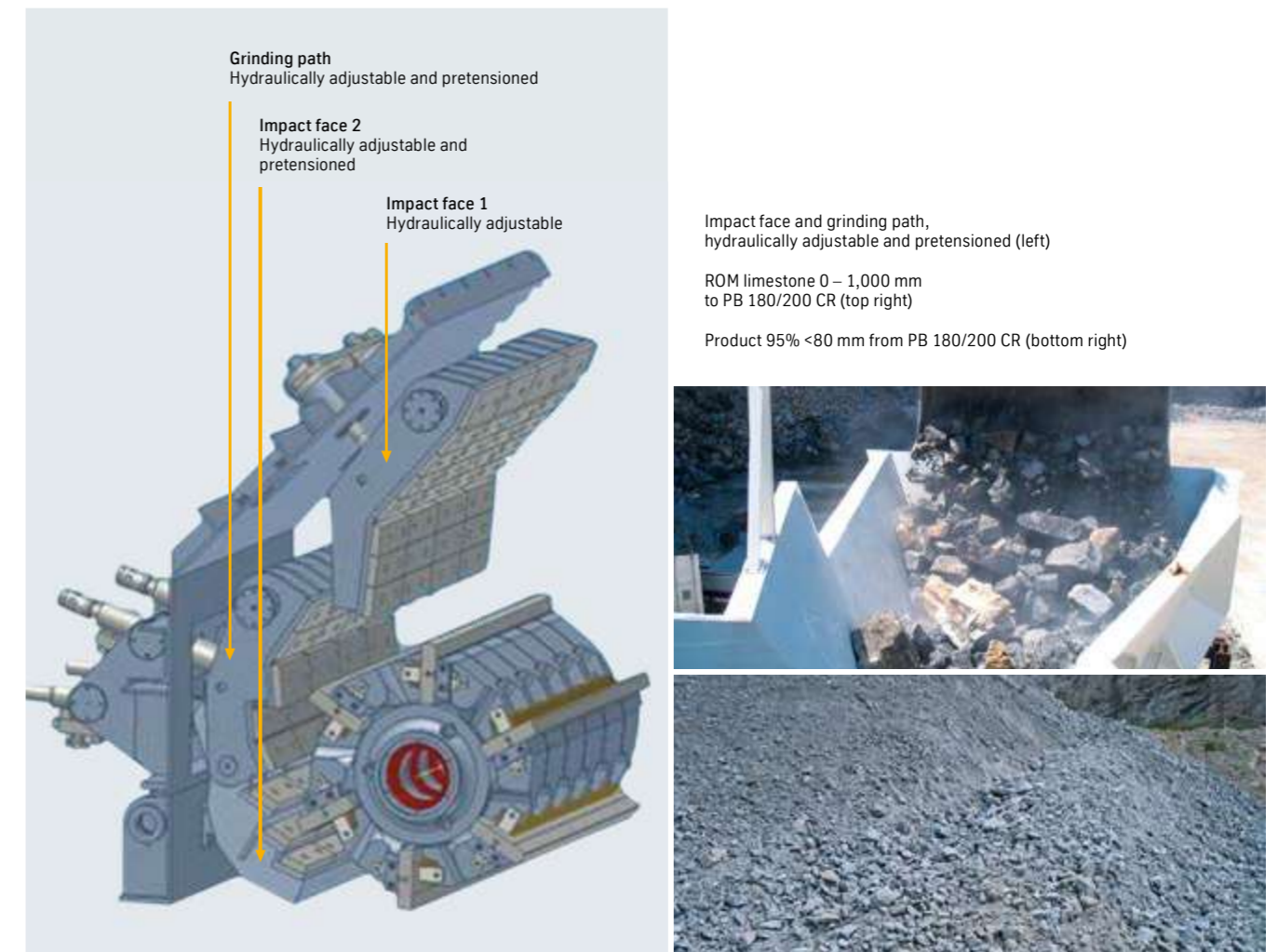

The advantages of thyssenkrupp impact crushers

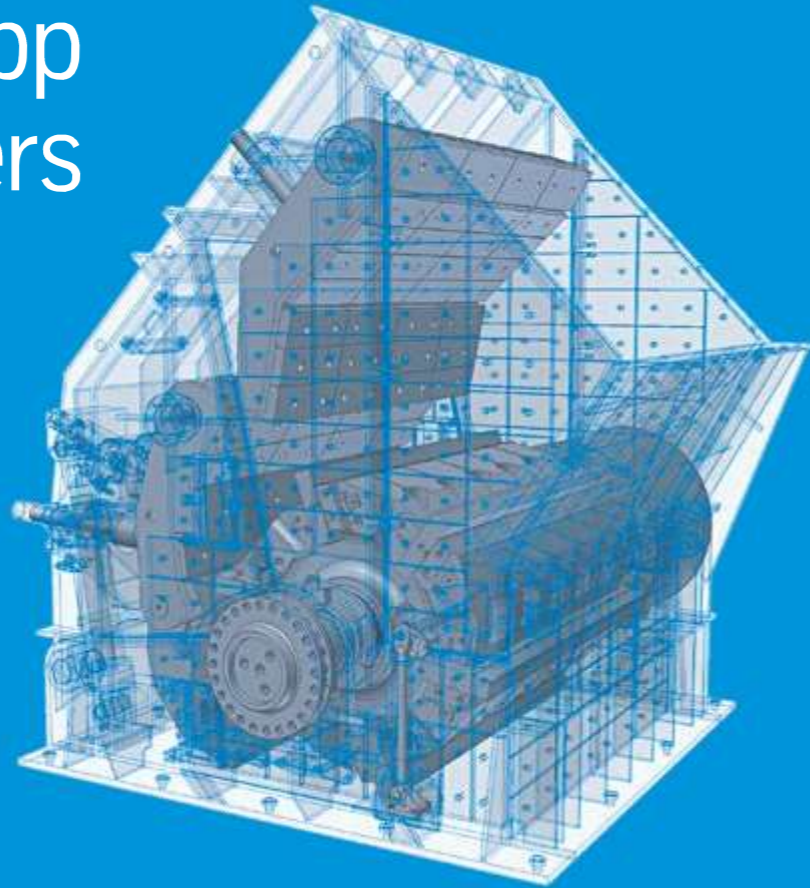

- ➞ Optimized cast rotor
- ➞ Hydraulic gap adjustment
- ➞ Impact face combined with grinding path
- ➞ Effective tramp iron protection
- ➞ Hydraulically loaded impact bars
- ➞ Interchangeable wear plates
- ➞ Split shell
- ➞ Maintenance-friendly design

Technical data

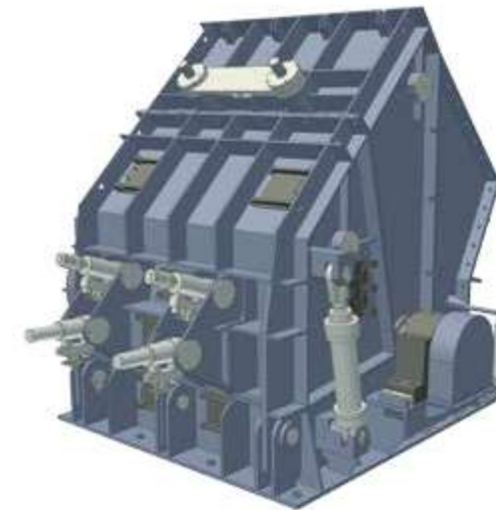

The given data are intended as a guide.

They depend on the crushing job (feed characteristics, product requirements) and the crusher configuration.

Throughput data for the given crushing job can be defined if required.

To keep pace with technical progress, we reserve the right to make improvements to the various machine types without prior notice.

Primary impact crusher

Type	Impact circle diameter [mm]	Rotor width [mm]	Feed opening [mm]	Throughput rate [t/h]
PB 160/150 CR	1,600	1,500	1,410 x 1,520	400
PB 160/200 CR	1,600	2,000	1,410 x 2,020	650
PB 180/200 CR	1,800	2,000	1,640 x 2,030	800
PB 180/250 CR	1,800	2,500	1,640 x 2,530	1,000
PB 200/200 CR	2,000	2,000	1,845 x 2,030	1,100
PB 200/250 CR	2,000	2,500	1,845 x 2,530	1,300
PB 200/300 CR	2,000	3,000	1,845 x 3,030	1,500
PB 220/250 CR	2,200	2,500	1,950 x 2,530	1,700
PB 220/300 CR	2,200	3,000	1,950 x 3,030	2,000
PB 250/250 CR	2,500	2,500	2,150 x 2,530	1,850
PB 250/300 CR	2,500	3,000	2,150 x 3,030	2,500

Secondary impact crusher

Type	Impact circle diameter [mm]	Rotor width [mm]	Feed opening [mm]	Throughput rate [t/h]
PB 100/100	1,000	1,000	710 x 1,060	110
PB 100/125	1,000	1,250	710 x 1,310	145
PB 125/125	1,250	1,250	950 x 1,310	230
PB 125/150	1,250	1,500	950 x 1,560	275
PB 140/150	1,400	1,500	1,000 x 1,560	330
PB 140/175	1,400	1,750	1,000 x 1,810	400
PB 140/200	1,400	2,000	1,000 x 2,060	450
PB 140/250	1,400	2,500	1,000 x 2,560	550
PB 140/300	1,400	3,000	1,000 x 3,060	650

Maintenance-friendly design

Quick-release bolts
allow the crusher shell to be easily opened



Devices for positioning the rotor and for raising the impact bars
to allow the impact bars to be turned and replaced safely and easily

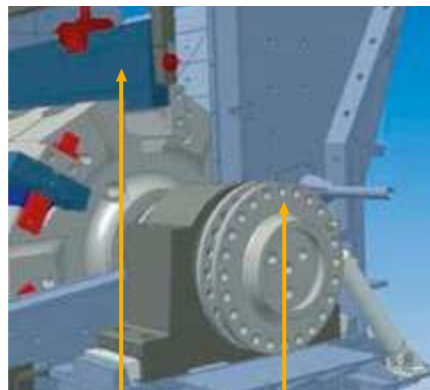

Device for raising the impact bars Device for positioning the rotor



Split shell
To provide optimum access to the impact faces, the crusher shell can be swung open hydraulically.

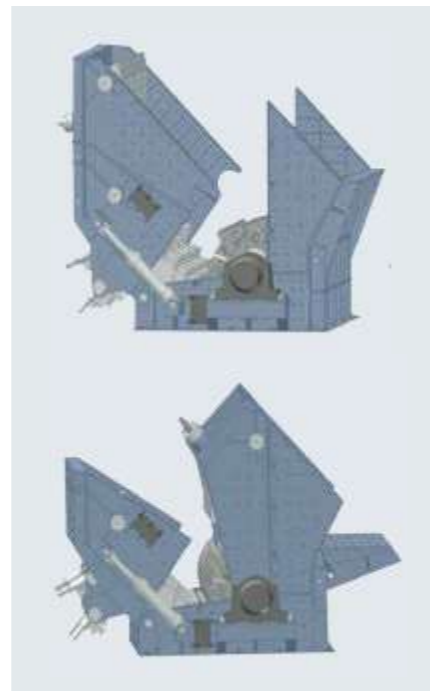

Our services keep things running smoothly!

We offer our customers not only optimum, customized technical solutions, but also comprehensive, tailored services ranging from the engineering of a crushing plant to their operation, and modification if needed.

We usually start out by analyzing the storage areas and the feed material. Using state-of-the-art processes we characterize the respective material, which forms the basis for selecting the right crusher and any customer-specific adaptations that may be required.

If you have a crushing system in operation, the maintenance and repair crews from thyssenkrupp Industrial Solutions are on hand whenever you need us to cater to your needs, from specialist advice, inspections and modifications through modernizations and performance enhancement to damage analyses and repairs, which are performed exclusively by our highly qualified assembly personnel using high-quality, certified spare parts. Alternatively, you can opt to have your crushers maintained and repaired at our workshops. You can call on these services not only for crushers from our own production lines, but also for systems manufactured by other suppliers.

Increase the productivity of your machines and plants! Our Services will assist you in doing so.

One-stop-shop service

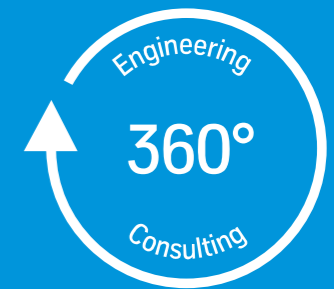

-  Asset Management
-  Spare Parts Supply & Management
-  Service Center & Field Services
-  Revamps



From top:

thyssenkrupp control and diagnostic system

Spare parts store

Whether the spare parts are to be collected by the customer or by air freight, we liaise with you to find the quickest and most cost-effective shipping option.

**Curious to find out more?
Contact us:**

thyssenkrupp Industrial Solutions AG
Business Unit Polysius

Graf-Galen-Straße 17
59269 Beckum, Germany
Phone: +49 (0)2525 – 99 9055
Mail: service.cement@thyssenkrupp.com
www.thyssenkrupp-polysius.com

engineering.tomorrow.together.